

DETAIL K

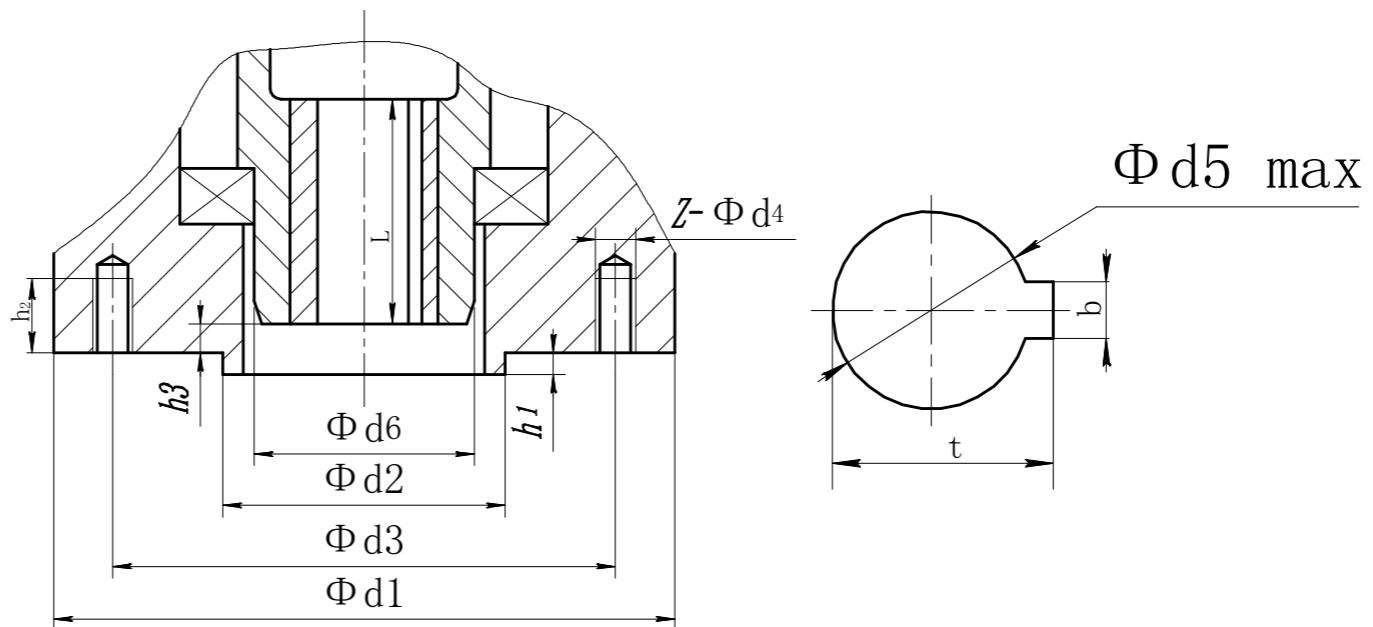

Code	Zahlenwert
$\varnothing d_1$	$\varnothing 210$
$\varnothing d_2 \text{ f8}$	$\varnothing 130$
$\varnothing d_3$	$\varnothing 165$
$\varnothing d_4$	M20
$\varnothing d_5 \text{ H9}$	$\varnothing 40$
$\varnothing d_5 \text{ max}$	$\varnothing 55$
$\varnothing d_6$	$\varnothing 100$
$h_1$	5
$h_2$	30
$h_3$	2
$t$	43.3
$b$	12
$Z$	4
$L$	80

Alle Maße in mm  
All dimensions in mm

Für alle übrigen Maße der Stellantriebe/Getriebe siehe Maßblatt neuester Ausgabe  
For all other dimensions of actuators/gear boxes refer to latest issue of dimension sheet

DIMENSIONS

M100/02.05

SM(R)100-SC02-F16-B3

	Datum	Name
Bearb.	2018.09.18	uffner
Gepr.	2018.09.18	Gerbig

**SCHWARZ®**

SCHWARZ ACTUATOR GMBH  
WWW.SCHWARZ-TECH.COM