

DETAIL K

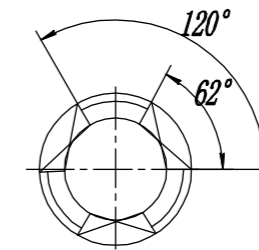
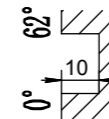
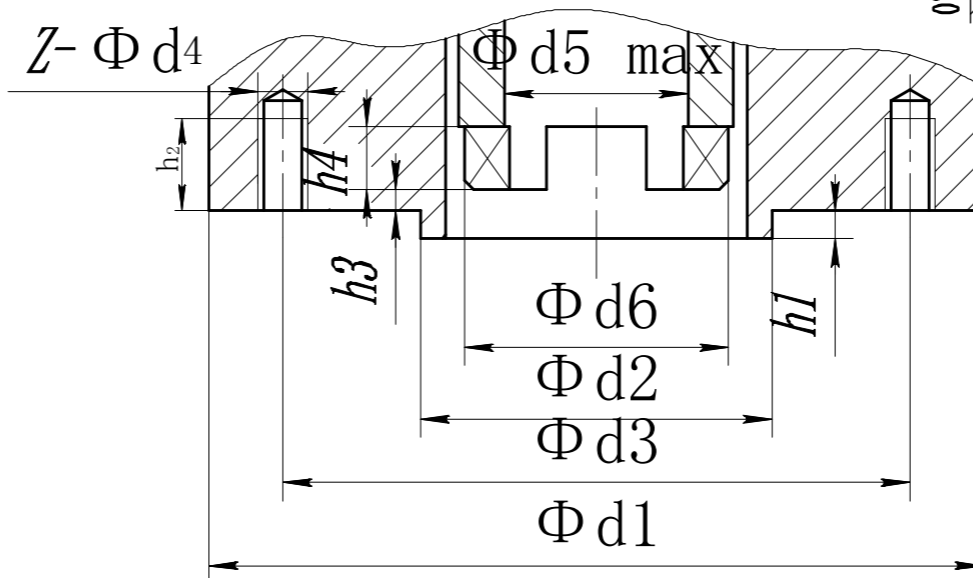

Code	Zahlenwert
$\phi d1$	$\phi 122$
$\phi d2$ H9	$\phi 70$
$\phi d3$	$\phi 102$
$\phi d4$	M10
$\phi d5$ max	$\phi 42$
$\phi d6$	$\phi 55$
h1	3
h2	15
h3	0
h4	10
Z	4

Alle Maße in mm
All dimensions in mm

Für alle übrigen Maße der Stellantriebe/Getriebe siehe Maßblatt neuester Ausgabe
For all other dimensions of actuators/gear boxes refer to latest issue of dimension sheet

DIMENSIONS

M.07/00.01

SM(R)07-F10-B

	Datum	Name
Bearb.	2018.09.18	uffner
Gepr.	2018.09.18	Gerbig

SCHWARZ[®]

SCHWARZ ACTUATOR GMBH
WWW.SCHWARZ-TECH.COM